



CHARGE CONTROLLER

CCS9620SL-F

Datasheet

Applications for the CCS-System :

Alarm Systems, Cellular Phones, Computer, Electric Vehicles, HiFi, Hobby, Instruments, Lamps, Medical Electronics, Pager, Portables, Radio, Solar Systems, Telephone, Tools, Toys, UPS, Video..

Special Features

- ☉ Tuned for SLA-Batteries
- ☉ Low threshold (S2o;S2i)
- ☉ Low power 0.1mA
- ☉ Power source - DC or AC (rectified 50/60Hz)
- ☉ Wide battery capacity range (1:16)
- ☉ External charge and buzzer enable

CCS Basic Features:

- ☉ Microcomputer controlled quickcharge up to 100% exactly
- ☉ CCS charge termination
- ☉ No overcharge, no memory effect, no gassing
- ☉ Extended battery life
- ☉ Independent of battery type: lead-acid, sealed lead-acid (NiCd, NiMH, etc.)
- ☉ Number of cells unlimited
- ☉ Automatic recharge, MC controlled
- ☉ Independent of precharging state, no discharge needed
- ☉ Reliable function also with protection diodes in the battery pack
- ☉ Simple handling, fail-safe by watchdog control
- ☉ Independent of external influences (e.g. temperature)
- ☉ Improved start up characteristic on empty cells
- ☉ Battery fault detection (LED & buzzer signal)

Characteristics:

Supply voltage: 2.0V to 5.5V
 Low power: < 0.5 mA
 Package: DIL 18, SOIC18, SSOP 20

Operating temperature:
 Industrial: -40 to +85 °C
 Extended: -40 to +125 °C

Storage temperature: -65 to +150 °C

Block Diagram:

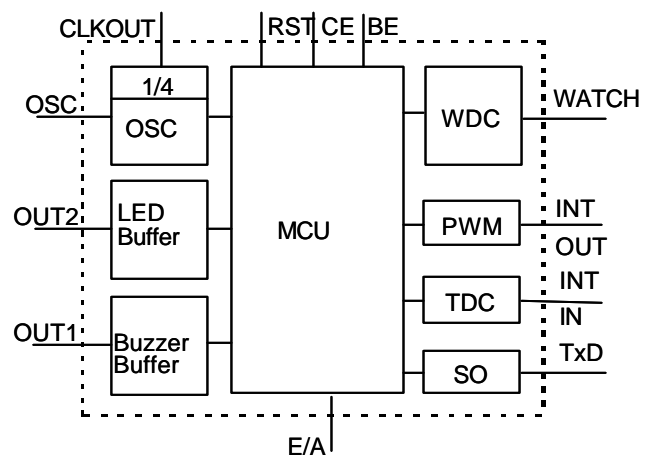

Pin Configuration:

1	OUT 1 (Buzzer)	10	TxD
2	WATCH	11	F.U.
3	F.U.	12	E/A
4	RST	13	OUT 2 (LED)
5	GND	14	V _{DD}
6	MT 1	15	CLKOUT
7	MT 2	16	OSC
8	BE, Buzzer-Enable	17	INTOUT, Integrator
9	CE, Charge-Enable	18	INTIN, Integrator

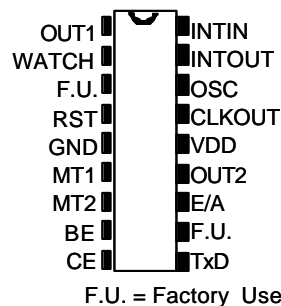

Absolute Maximum Ratings:	min.	max.	units
V _{DD}	0	6.5	V
Operating current I _{DD}	-	50	mA
I/O pins	-0.6	V _{DD} +0.6	V
INPUT-port pin-No. 4,6,7,8,9,16,18	-	+/- 500	μA
OUTPUT-port pin-No. 1,2,10,12,13,15,17	-	+/- 20	mA
Total power dissipation	-	800	mW

Supply: at 25°C	min.	typ.	max.	units
V _{DD}	2.0	5.0	5.5	V
Standby current (OUT1/2 n.c.)	-	0.1	0.5	mA
Characteristics: at 25°C	min.	typ.	max.	units
Input low-value	V _{SS}	-	0.15V _{DD}	V
Input high-value	0.25V _{DD} +0.8	-	V _{DD}	V
Input leakage current	-1	0.5	+1	μA
Output low-value (I _{OL} =8.5mA, V _{DD} =4.5V)	-	-	0.6	V
Output high-value (I _{OH} =-3.0 mA, V _{DD} =4.5V)	V _{DD} -0.7	-	-	V
RESET low-timing (pulse width)	2,000	-	-	ns
RC-oscillator (3k6@330pF or 10k@120pF)	530	625	737	kHz

Functional Description

The CCS controller with appropriate circuitry (e.g. LT1510, 1511) controls the charging of a rechargeable battery up to 100% of the available capacity. The inner impedance between electrode and electrolyte is used for the determination of the 100% full charge state (patented worldwide). In addition the CCS controller features a battery fault detection and an intelligent recharging procedure for maintaining charge in standby operation without derating the performance of the battery by memory effect. Automatic on/off switching of the charging current can be controlled by a fail-safe Watch Dog Circuit (WDC).

Power Source:

The calculation of the inner impedance requires a variable charging current. If a DC-power supply is used, the E/A (Pin) of the CCS9620 can drive a programmable current source to generate the needed waveform itself. By this a correct determination of the end of charge can be achieved.

Charge Current:

To ensure best results the parameters must remain inside their computational limits. Therefore the mean charging current should be stabilized around the typ. value C_A (see Table 1).

Battery Voltage:

In principle the controller is independent of cell voltage and number of cells. In every case the battery voltage is reduced by a voltage divider to normalized 1.26V at battery nominal voltage.

Process Timing:

When the power supply is switched on (t_0), the processor is in standby operation until the duty cycle on pin 17 (integrator out) is lower than limit S2o (battery is connected). Power on reset or battery insertion starts a "normal" charge cycle. LED=on (OUT2=H). When a battery connection is detected (t_1), the charge controller starts the measurement of the inner impedance and switches on a pulsating charging current (t_2). When the measurement of the inner impedance of the battery points to a 100% full charge, the processor switches off the charge current (t_3).

Battery Fault Detection:

- Overvoltage (open circuit): If the battery voltage exceeds the upper "limit S2i", the charging process stops immediately. The charging cycle will be restarted for a maximum of two times. If then the voltage is below that limit the charge process will continue, when it is still above the limit, the charge process is interrupted and the controller signals "Battery defective".
- Undervoltage (shorted cell): If the battery voltage is below the lower "limit S1" at moment t_4 (30 sec after charge termination t_3), the charging cycle will be restarted for a maximum of two times. If the voltage is still out of that range, the controller signals "Battery defective" (LED flashing). Nevertheless recharge will follow in every case, if the battery is not disconnected.

$S2i: V_{norm} = 1.68V$	$S2o: V_{norm} = 1.55V$	$S1: V_{norm} = 1.26V$
-------------------------	-------------------------	------------------------

Recharge:

The first recharge starts at moment t_5 . About 1hr after completion, one battery care cycle will begin and last for about 15-30 Minutes. LED=off (OUT2=L). The end is determined as mentioned before (t_7). The time interval to the next recharge is fixed. About 10 days after the first battery care cycle, the next battery care cycle is initiated and will last for about 15-30 Minutes. LED=off (OUT2=L). Charge LED is disabled during "battery care".

Standby:

Because of the intelligent recharge, even for the battery with load ($I_{Standby} < 0.2C_A$) a residual capacity of approx. 80% of the nominal capacity can be achieved at any time ($I_{Charge} = 1C_A$).

Additional Functions:

★DC-power control:

The controller generates the DC-input into the required waveform (frequency)

★Buzzer On/Off:

★Charge On/Off:

Every charge ON signal on Pin 9 means, that any battery will be treated as a just connected battery. With charge OFF on Pin 9 it is possible to stop the charge process.

★Selection of charge mode (time, current):

With pin 6 (MT1) and pin 7 (MT2) it is possible to select a slow or fast charge mode. The MT-setting is used for the CCS pattern recognition and determines the data collection window (comparable to the range at measurement devices), it is not a Maximum Time or Charge Current setting. With one and the same power source it is possible to charge batteries with low and batteries with high capacity. Status of Pin 6, 7 is accepted during initialization after Power On or Reset only.

Table 1: charge mode (charge time, charge current)

MT 2	MT 1	cycle time	charge current	typ.	charge time *	typ. *
Pin 7	Pin 6	sec	C_A	C_A	h	h
0	0	15	1/2 - 2	1	0.5 - 2	1
0	1	30	1/4 - 1	1/2	1 - 4	2
1	0	45	1/6 - 2/3	1/3	1.5 - 6	3
1	1	60	1/8 - 1/2	1/4	2 - 8	4

0 = low 1 = high

*time to full-charge an empty battery!

★Data transfer:

At Pin 10 binary encoded serial data are available. With the BTI-Adapter Chip these data can be decoded to ASCII (RS232). (See also application note AN935)

Process-Timing

t0-t1	Delay	Until battery is connected.
t1-t2	Measurement	Approx. 20 sec.
t2-t3	Charging	Until 100% fullcharge of the battery Time depends on precharging state and charging current From 1 min. to approx. 60 min. at 1C (see table 1)
t3-t4	Measurement	Approx. 30 sec
t4	Measurement	Battery fault detection
t4-t5	Delay	Until next recharge approx. 1 hour or 10 days (MC-controlled)
t5-t7	Charging	Recharge (similar to t1-t3)

CHARGE-DIAGRAM: FULLCHARGE OF A BATTERYPACK

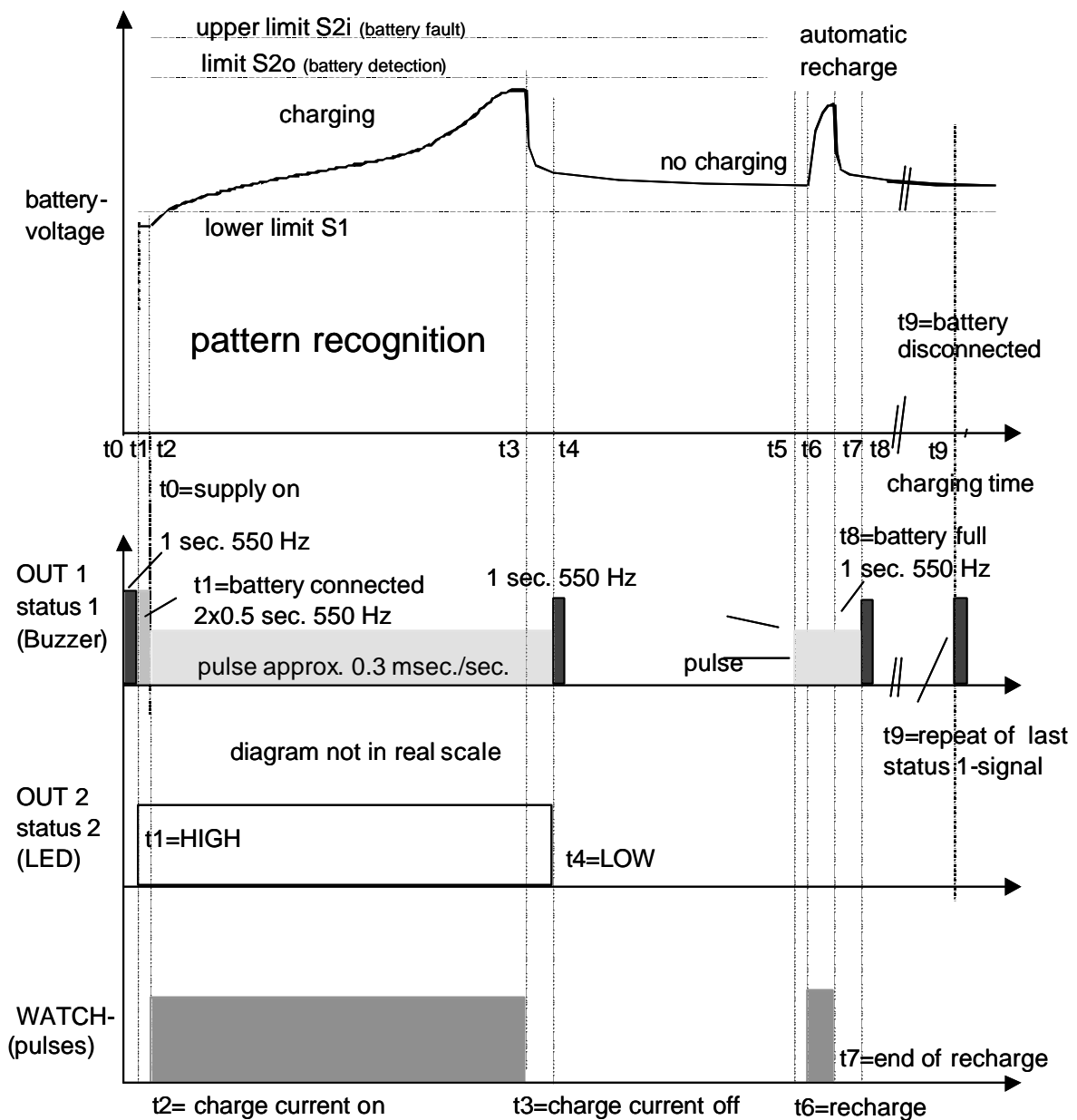

- Event t1: battery connected, measurement of the inner impedance of the battery for approx. 20 sec
- Event t2: start with battery charging
- Event t3: end of charge, automatic cut controlled by controller, battery must not be disconnected
- Event t4: end of measurement approx. 30 sec after full charge recognition
- Event t5: automatic recharge, μ P controlled
- Event t6: battery recharging
- Event t7: end of recharge
- Event t8: end of measurement approx. 30 sec after full charge recognition
- Event t9: battery disconnected

Pin Description

Pin 5	GND	Ground
Pin 14	V _{DD}	Positive input voltage
Pin 4	RST	GND = RESET / V _{DD} (Pull-up) = program start rising edge to V _{DD} , RESET-TIME = 18 msec
Pin 16	OSC	R/C oscillator input (625 kHz \pm 18%)
Pin 15	CLKOUT	Oscillator output (1/4 f _{OSC} approx. 156 kHz / 6,4 μ sec \pm 18%)
Pin 17	INTOUT	Integrator output: pulse, period T = 52 msec \pm 18% Duty cycle (H/T) < 31%...battery connected, limit S2o (V _{norm} = 1.68V) Duty cycle (H/T) approx. 23% to 31%... measurement, battery full Duty cycle (H/T) < 23%...battery fault, limit S1 (V _{norm} = 1.26V) Duty cycle (H/T) over 29%...battery fault, no battery
Pin 18	INTIN	Integrator input
Pin 2	WATCH	Control output for charging current (off = 0V, on = 5V approx. 16 kHz)
Pin 1	OUT 1 (Buzzer)	Status indicator 1 (square wave 0V-5V) Supply "ON": approx. 1 sec. 550 Hz Battery connected: approx. 2x0.5 sec. 550 Hz Charging cycle: pulses approx. 0.3 msec./sec. Battery full: approx. 1 sec. 550 Hz Interrupt of charging: approx. 3x (2x0.5 sec.) 550 Hz Battery fault: approx. 5x0.5 sec. 550 Hz Battery disconnected: repetition of the last signal
Pin 13	OUT 2 (LED)	Status indicator 2 (level 0V-5V) Battery connected: output HIGH Charging cycle: output HIGH Recharge cycle: output LOW Battery full: output LOW Battery fault: 1 Hz pulses until next recharge
Pin 8	BE	Buzzer enable: On/Off during charge process, Level is detected, reaction max. 15 sec later Pin HIGH: buzzer activated Pin LOW: buzzer not active
Pin 9	CE	Charge enable: charge process On/Off, Level is detected, reaction 1 sec later Pin HIGH: charge process on Pin LOW: charge process off
Pin 12	E/A	Charge current ON/OFF
Pin 6	MT 1	Selection of charge mode: see table 1, detected at Reset
Pin 7	MT 2	Selection of charge mode: see table 1, detected at Reset
Pin 10	TxD	Serial data out, via BTI-Adapter to PC

Pin 16: For a new design use R6=3k6 and C6=330pF, oscillator is more stable!

Pin 6,7 (see Table 1) and 8,9 must be connected to 0V or 5V!

Do not connect F.U. Pins!

Application for DC-supply:

Power Source:

As supply voltage V_{in} use DC-Input, e.g. LT1510CS

For the application with the LT1510CS V_{in} must be at least more than 12V DC and at least more than 7V higher than the nominal battery voltage, to guarantee a stable current.

R9 Battery Voltage:

Nominal battery voltage (V_{nom} , V_{bat}) must be divided to 1,2V by the resistor divider R9/R10 for correct resolution of the CCS-Charge-Controller.

$$V_{nom} = 1,2 * \left(1 + \frac{R_9}{R_{10}} \right) \quad R_9 = R_{10} * \left(\frac{V_{nom}}{1,2} - 1 \right)$$

The following table shows typical values for R9 @R10=33k

V_{nom}	1,2	2	2,4	3,6	4	4,8	6	7,2	8	8,4	9,6	10	12	V
R9(R10=33)	0	22	33	68	74	100	130	160	187	200	237	240	297	k Ω

R17 Maximum Voltage:

Maximum Voltage is limited by the OVP-input of the LT1510. Battery voltage is divided by resistors R17/R3 and compared to the internal reference of 2,465V. Battery Terminal voltage is limited to a value of

$$V_{max} = 2,465 * \left(1 + \frac{R_{17}}{R_3} \right) \quad R_{17} = R_3 * \left(\frac{V_{max}}{2,465} - 1 \right)$$

R1 Charging Current:

Battery charging current $I_{ch}=2000 * I_{bias}$ The bias current is determined by the LT1510 internal reference of 2,465V divided by the sum of (R1+R2). The 6:44 ms current modulation of CCS96205 results in a 14% mean current reduction.

The formula for the charging current is:

$$I_{ch} = \frac{2,465 * 2000 * 0,86}{R_1 + R_2} \quad I_{ch} = \frac{4,24}{2,7 + R_1 [k\Omega]} [A]$$

The table shows typical values for R1 @R2=2k7

R1	0,68	1,5	2,2	3,3	5,6	10	15	33	39	k Ω
I_{ch}	1,250	1,000	860	707	511	333	240	120	100	mA

Schematic for DC-supply:

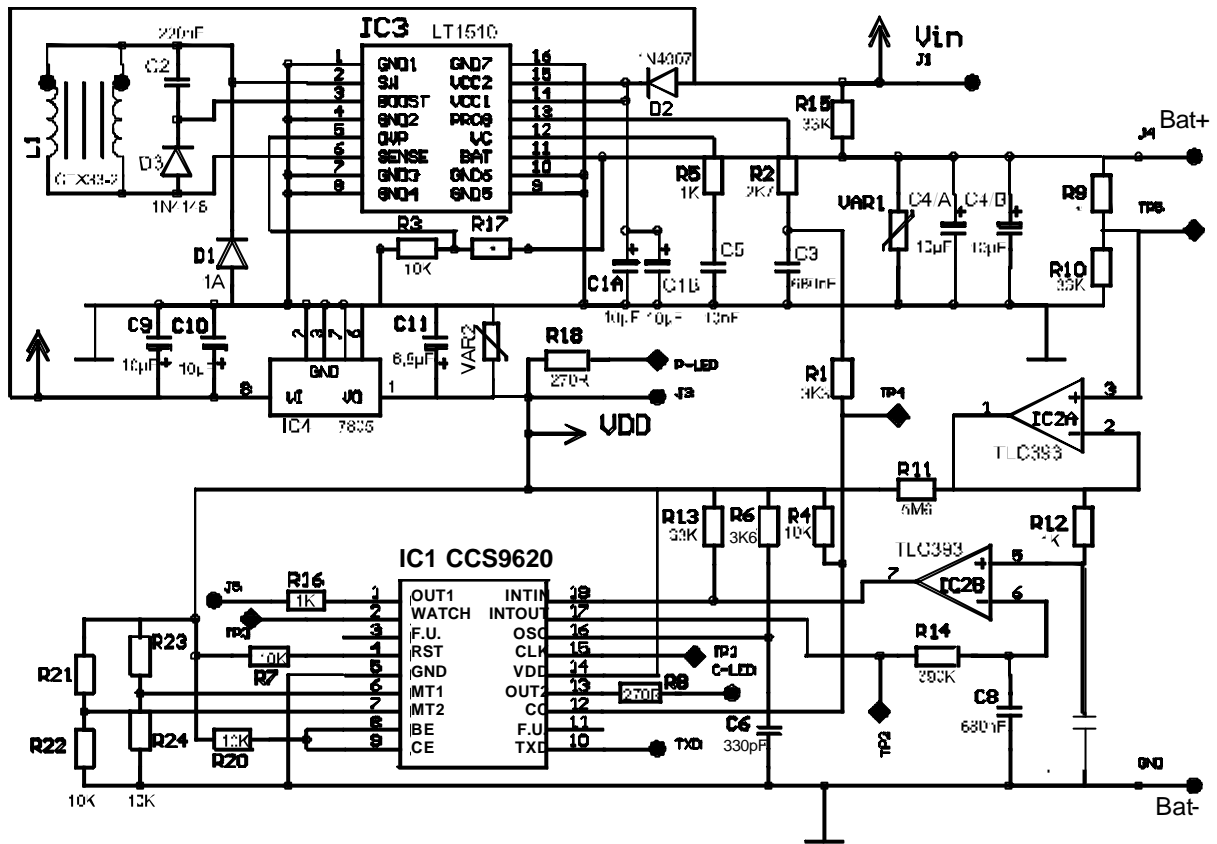

Application: for rectified AC-supply

Power Source:

The circuit must be supplied with a full bridge rectifier - **no smoothing capacitor!** As supply voltage V_{in} use a rectified 50/60 Hz AC voltage pulsating with a 100/120 Hz frequency.

R9 Battery Voltage:

Number of cells unlimited

$$R9 = R10 \times [(V_{\text{Battery}} / 1.2) - 1]$$

$$V_{\text{Battery}} = 1.2 \times [1 + (R9 / R10)]$$

R9@R10=33k

Batt. nom. Voltage	1.2	2.4	3.6	4.8	6.0	7.2	8.4	9.6	10.8	12.0	V=
Number of cells	1	2	3	4	5	6	7	8	9	10	
Resistor R9	1	34	67	100	133	166	199	232	265	298	kOhm
V_{in} typ.	9	9	9	10	12	14	16	18	20	22	V_{eff}

R8,R19 Charge Current:

$I_{\text{charge}} = U_{\text{ref}} / \text{Resistor R8 parallel R19}$ with $U_{\text{Ref}} = 0,38\text{V}$

Examples:

Icharge	100	500	1,000	2,000	3,000	mA
Resistor R8//R19	3.9	0.76	0.38	0.19	0.13	Ohm

Pin 6, 7 Charge Mode: Selection of charge current see table 1, page 3.

Schematic for rectified AC-supply

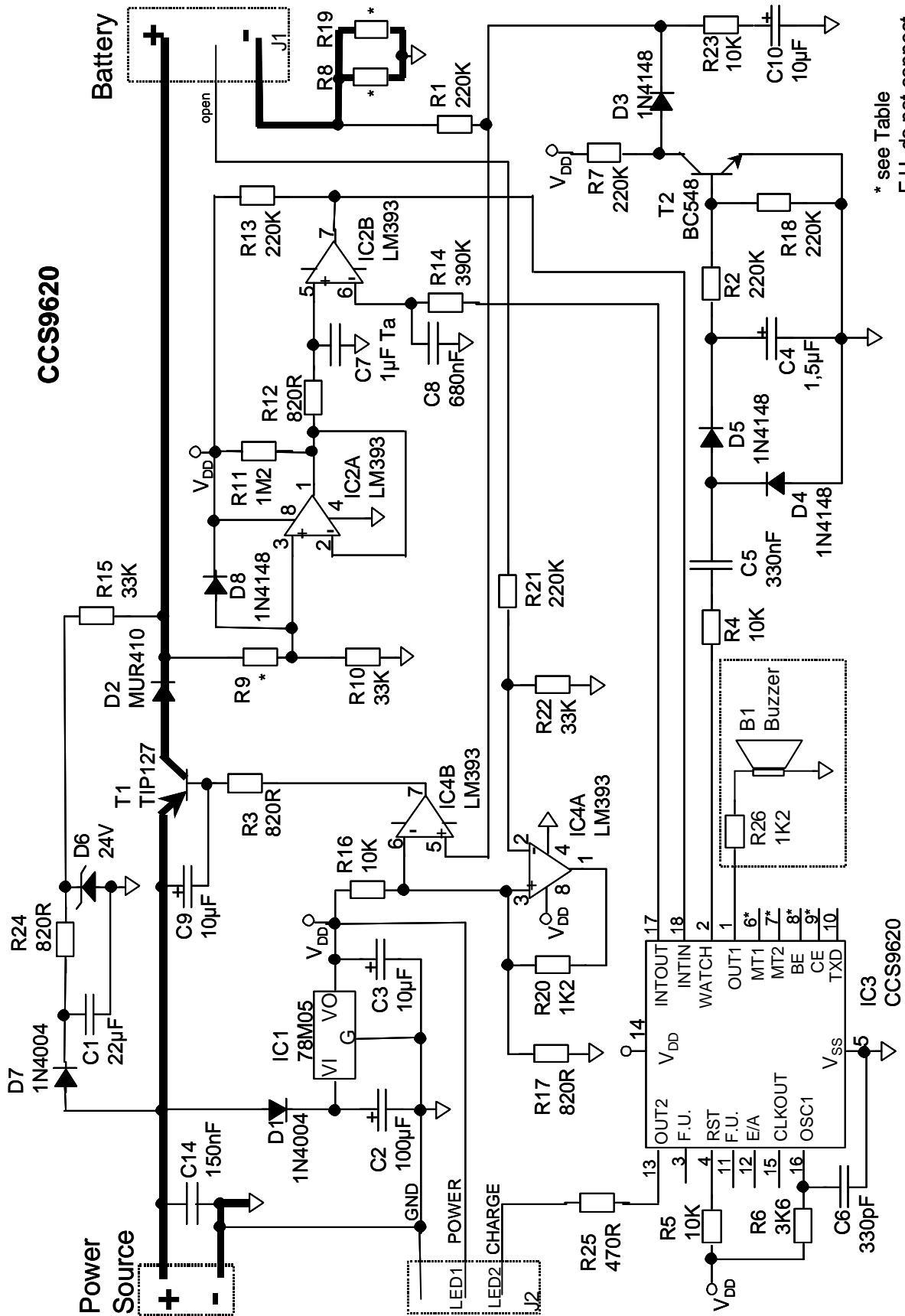

* see Table
F.U. do not connect

Operating Instructions:

- 1) Power supply on: 1 beep, green LED (LED 1) on (standby).
- 2) Battery connected: 2 short beep, red LED (LED 2) on. (not protected against false polarity!)
- 3) Battery fully charged: 1 short beep, red LED off.
- 4) Battery fault: 5 short beep, red LED flashing.
- 5) Interrupt: 3 times 2 short beep.
- 6) Battery disconnected: Last signal repeated (full or defective).
- 7) During charge: Click with 1 sec period, red LED on (if BE = high)
- 8) During recharge: Click with 1 sec period, red LED off (if BE = high)

Package:

18 - Lead Plastic Dual In-line **DIP 18**

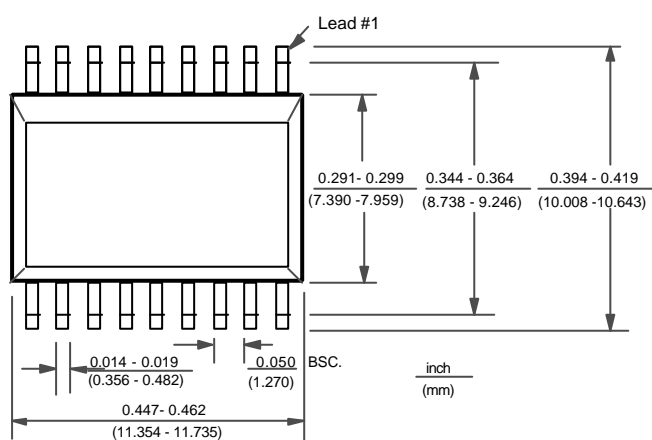
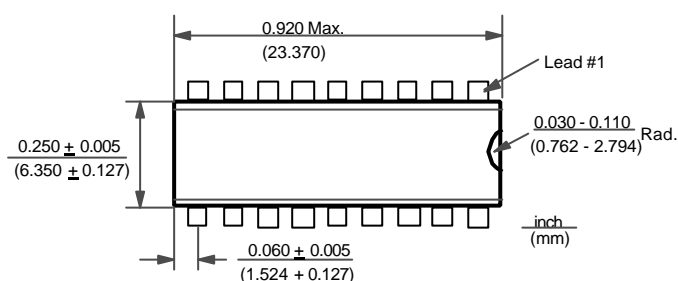

18 - Lead Plastic Surface Mount SOIC -Wide **SMD**

Sales office:

Producer:

≡ BTI ≡ Rudolfstrasse 14
A-8010 Graz, AUSTRIA
Tel: (+43/316) 32 60 31
Fax: (+43/316) 38 18 08
e-mail: info@bticcs.com
<http://www.bticcs.com>

BTI does not assume any responsibility for use of any circuitry described, no circuit patent licenses are implied.
BTI reserves the right, at any time without notice, to change said circuitry or specifications.