



CHARGE CONTROLLER

CCS9505

Datasheet

Applications for the CCS-System:

Alarm Systems, Cellular Phones, Computer, Electric Vehicles, HiFi, Hobby, Instruments, Lamps, Medical Electronics, Pager, Portables, Radio, Solar Systems, Telephone, Tools, Toys, UPS, Video..

Special Features

- ☺ Charge mode selection, wide battery capacity range (1:16)
- ☺ Battery protection against total discharge
- ☺ External charge enable, external buzzer enable
- ☺ Additional status output
- ☺ PC-Interface

CCS Basic Features:

- ☺ Microcomputer controlled quickcharge up to 100% exactly in 20-30 minutes
- ☺ CCS charge termination
- ☺ No overcharge, no memory effect
- ☺ Extended battery life, >5000 cycles
- ☺ Independent of battery type: NiCd, NiMH, Lead Acid (Pb), etc.
- ☺ Number of cells unlimited
- ☺ Automatic recharge, MC controlled
- ☺ Standby operation
- ☺ Independent of precharging state, no discharge needed
- ☺ Reliable function also with protection diodes in the battery pack
- ☺ Simple handling, fail-safe by watchdog control
- ☺ Independent of external influences (e.g. temperature)
- ☺ Improved start up characteristic on empty cells
- ☺ Battery fault detection (LED & buzzer signal)

Characteristics:

Input voltage: 3V to 5.5V
 Low power: < 2 mA
 Package: PDIP 18, SOIC 18, SSOP 20

Operating temperature:
 Commercial: 0 to +70 °C
 Industrial: -40 to +85 °C

Storage temperature: -65 to +150 °C

Block Diagram:

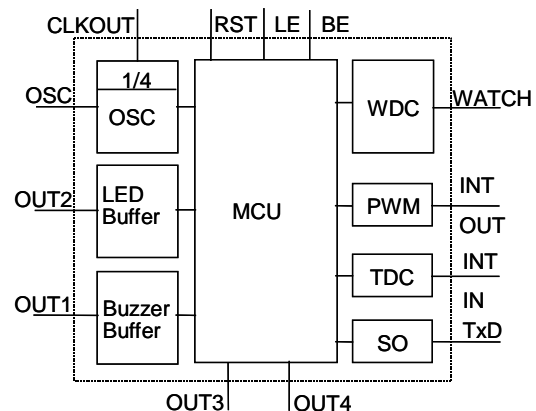

Pin Configuration:

1	OUT 1 (Buzzer)	10	TxD
2	WATCH	11	OUT 3
3	F.U.	12	OUT 4
4	RST	13	OUT 2 (LED)
5	GND	14	V _{DD}
6	MT 1	15	CLKOUT
7	MT 2	16	OSC
8	BE, Buzzer-Enable	17	INTOUT, Integrator
9	LE, Charge-Enable	18	INTIN, Integrator

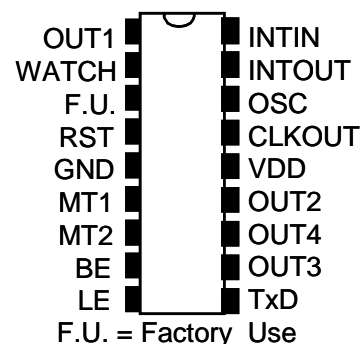

Absolute Maximum Ratings:	min.	max.	units
V _{DD}	0	5.5	V
Operating current I _{DD}	-	50	mA
I/O pins	-0.6	V _{DD} +0.6	V
INPUT-port pin-No. 4,6,7,8,9,16,18	-	+/- 500	μA
OUTPUT-port pin-No. 1,2,10,11,12,13,15,17	-	+/- 20	mA
Total power dissipation	-	800	mW

Supply: at 25°C	min.	typ.	max.	units
V _{DD}	3.0	5.0	5.5	V
Standby current (OUT1/2 n.c.)	-	1.8	3.3	mA
Characteristics: at 25°C	min.	typ.	max.	units
Input low-value	V _{SS}	-	0.2V _{DD}	V
Input high-value	0.2V _{DD} +1	-	V _{DD}	V
Input leakage current	-1	0.5	+1	μA
Output low-value (I _{OL} =8.7mA, V _{DD} =4.5V)	-	-	0.6	V
Output high-value (I _{OH} =-5.4mA, V _{DD} =4.5V)	V _{DD} -0.7	-	-	V
RESET low-timing (pulse width)	100	-	-	ns
RC-oscillator (3k6@330pF or 10k@120pF)	530	625	737	kHz

Functional Description

The CCS controller with appropriate circuitry controls the charging of a rechargeable battery up to 100% of the available capacity. The inner impedance between electrode and electrolyte is used for the determination of the 100% full charge state (patented worldwide). In addition the CCS Processor features a battery fault detection and an intelligent recharging procedure for maintaining charge in standby operation without derating the performance of the battery by memory effect. Automatic on/off switching of the charging current is controlled by a fail-safe Watch Dog Circuit (WDC).

Power Source:

For the calculation of the inner impedance (according to the new process) it is essential, that the power is supplied with the sinusoidal 100/120Hz pulsation of the rectified line current. Although the battery is charged correctly in many cases, the use of a DC current may not prevent in every condition from uncertain calculations which may lead to premature shut off, overloading, excessive heating and damage of the battery and surrounding material. Therefore the use of a smoothing capacitor as well as the operation from a DC supply (battery) is strictly forbidden.

Charge Current:

To ensure best results it is necessary that the parameters remain inside their computational limits. Therefore the mean charging current should be stabilized around the typ. value C_A (see table 1).

Battery Voltage:

In principle the controller is independent of cell voltage and number of cells. In every case the battery voltage is reduced by a voltage divider to normalized 1.26V at battery nominal voltage.

Process Timing:

The moment, the power supply is switched on (t₀), the controller is in standby operation until the duty cycle on pin 17 (integrator out) is lower than 37% (battery is connected). When a battery connection is detected (t₁), the CCS9505 starts the measurement of the inner impedance and switches on a pulsating charging current (t₂). When the measurement of the inner impedance of the battery points to a 100% full charge, the controller switches off the charge current (t₃).

Battery Fault Detection:

a) Over voltage (open circuit): If the battery voltage exceeds the upper "limit S2", the charging process stops immediately. The charging cycle will be restarted for a maximum of two times. If then the voltage is below that limit the charge process will continue, when it is still above the limit the charge process is interrupted and the controller signals "Battery defective".

S2: e.g. for NiCd $V_{nom.} = 1,2V$ 166% of $V_{nom} = 1,99V$ / cell

b) Under voltage (shorted cell): If, at moment t4, which is 30 sec after charge termination t3, the battery voltage is below a defined lower "limit S1", the charging cycle will be restarted for a maximum of two times. If the voltage is still out of that range, the controller signals "Battery defective" (LED flashing). If the battery is not disconnected, recharge will follow in every case.

S1: e.g. for NiCd $V_{nom.} = 1,2V$ 105% of $V_{nom} = 1,26V$ / cell

Recharge:

The first recharge starts at moment t5. The shut off is detected by measurement of the inner impedance of the battery as mentioned before (t7). The time distance to the next recharge is determined by the controller.

Standby:

Because of the intelligent recharge, even for the battery with load ($I_{Standby} < 0.2C_A$) a residual capacity of approx. 80% of the nominal capacity can be achieved any time ($I_{Charge} = 1C_A$).

Additional Functions:

★ Battery protection: To protect the batteries against total discharge during standby operation, the charge process will start automatically when the battery voltage sinks below 1V/cell.

★ Selection of charge mode (time, current): With pin 6 (MT1) and pin 7 (MT2) it is possible to select a slow or fast charge mode. The MT-setting is used for the CCS pattern recognition and determines the data collection window (comparable to the range at measurement devices), it is **not** a Maximum Time or a Charge Current setting. With one and the same power source it is possible to charge batteries with low and batteries with high capacity. Status of Pin 6, 7 is accepted during initialization after Power On or Reset only..

Table 1: charge mode (charge time, charge current)

MT 2	MT 1	cycle time	charge current	typ.	charge time *	typ. *
Pin 7	Pin 6	sec	C_A	C_A	h	h
0	0	15	1/2 - 2	1	0.5 - 2	1
0	1	30	1/4 - 1	1/2	1 - 4	2
1	0	45	1/6 - 2/3	1/3	1.5 - 6	3
1	1	60	1/8 - 1/2	1/4	2 - 8	4

0 ... low ... 1 high

*max. time for a fullcharge of an empty battery!

★ Additional status output: Pin 11 and Pin 12

Table 2: additional status output

Pin 12	Pin 11	definition
Status 4	Status 3	definition
0	0	standby (no battery)
0	1	charging process
1	0	battery defective
1	1	charge OK (battery full)

0 ... low 1 ... high

★ Data transfer: With Pin 10, a graphical presentation and recording of the parameters via BTI-Adapter from the charging circuitry to the PC is possible.

★ Buzzer On/Off:

★ Charge On/Off: Every charge ON signal on Pin 9 means, that any battery will be treated as a just connected battery. With charge OFF on Pin 9 it is possible to stop the charge process.

Pin Description

Pin 5	GND	Ground
Pin 14	V _{DD}	Positive input voltage
Pin 4	RST	GND = RESET / V _{DD} (Pull-up) = program start rising edge to V _{DD} , RESET-TIME = 18 msec
Pin 16	OSC	R/C oscillator input
Pin 15	CLKOUT	Oscillator output (1/4 f _{OSC})
Pin 17	INTOUT	Integrator output: pulse, period T = 52 msec ± 18% Duty cycle (H/T) < 37%...battery connected Duty cycle (H/T) approx. 23% to 37%... measurement, battery full Duty cycle (H/T) < 23%...battery fault, limit S1 Duty cycle (H/T) over 37%...battery fault, limit S2, no battery
Pin 18	INTIN	Integrator input
Pin 2	WATCH	Control output for charging current (off = 0V, on = 5V approx. 16 kHz)
Pin 1	OUT 1 (Buzzer)	Status indicator 1 (square wave 0V-5V) Supply "ON": approx. 1 sec. 550 Hz Battery connected: approx. 2x0.5 sec. 550 Hz Charging cycle: pulses approx. 0.3 msec./sec. Battery full: approx. 1 sec. 550 Hz Interrupt of charging: approx. 3x (2x0.5 sec.) 550 Hz Battery fault: approx. 5x0.5 sec. 550 Hz Battery disconnected: repetition of the last signal
Pin 13	OUT 2 (LED)	Status indicator 2 (level 0V-5V) Battery connected: output HIGH Charging cycle: output stays HIGH Battery full: output LOW Battery fault: 1 Hz pulses until next recharge
Pin 8	BE	Buzzer enable: On/Off during charge process, Level is detected, reaction max. 15 sec later Pin HIGH: buzzer activated Pin LOW: buzzer not active
Pin 9	LE	Charge enable: charge process On/Off, Level is detected, reaction 1 sec later Pin HIGH: charge process on Pin LOW: charge process off
Pin 11	OUT 3	Status output: see table 2
Pin 12	OUT 4	Status output: see table 2
Pin 6	MT 1	Selection of charge mode: see table 1, the configuration is detected at t ₀
Pin 7	MT 2	Selection of charge mode: see table 1, the configuration is detected at t ₀
Pin 10	TxD	Serial data out, via BTI-Adapter to PC

Pin 16: For a new design use R6=3k6 and C6=330pF, oscillator is more stable.

Pin 6,7 (see table 1) and 8,9 (see table 2) must be connected to 0V or 5V!

Do not connect F.U. Pins!

CHARGE-DIAGRAM: FULLCHARGE OF A BATTERYPACK

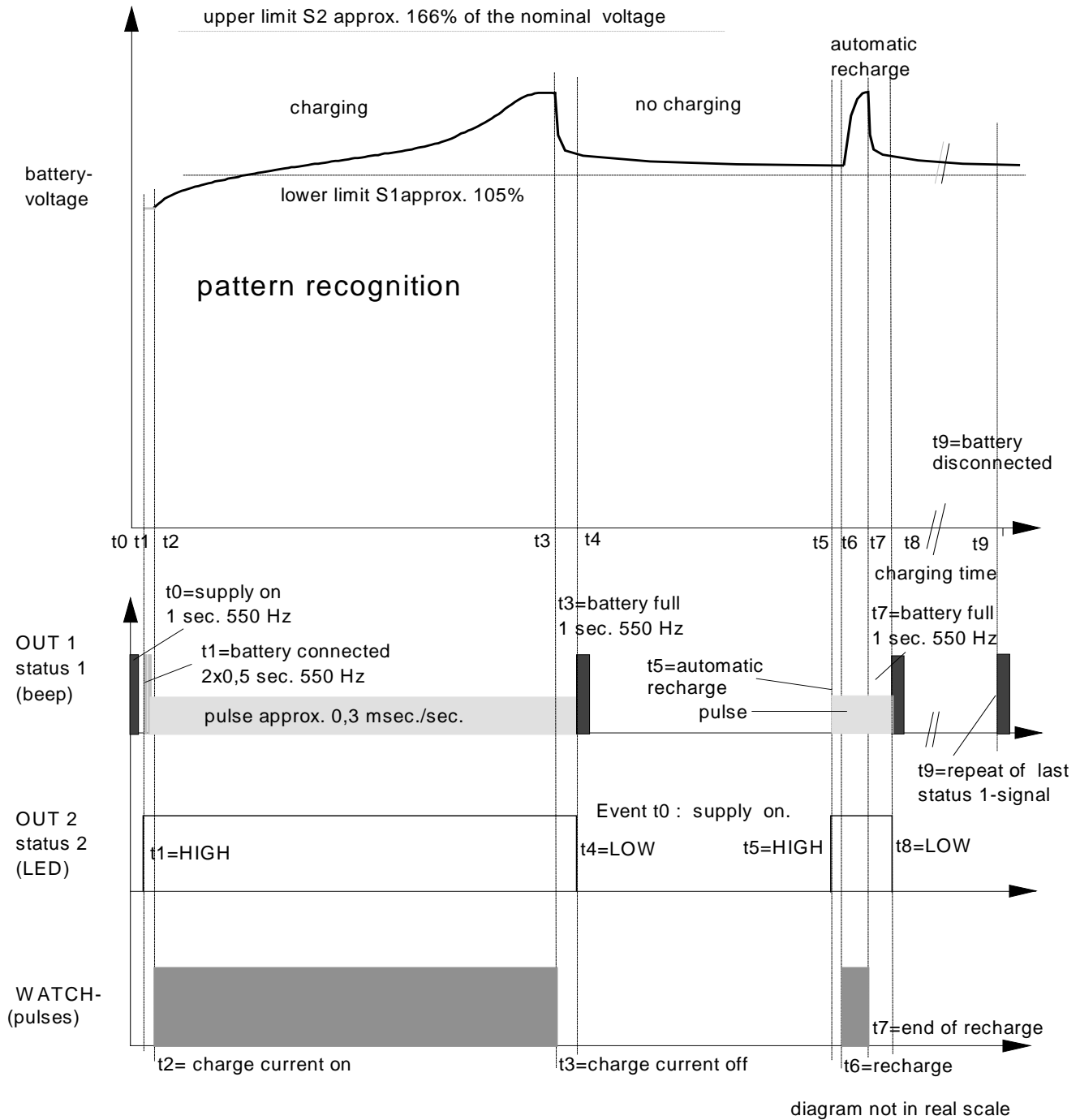

- Event t1 : battery connected, measurement of the inner impedance of the battery for approx. 20 sec.
- Event t2 : start with battery charging
- Event t3 : end of charge, automatic cut off controlled by the processor, battery must not be disconnected
- Event t4 : end of measurement approx. 30 sec after fullcharge recognition
- Event t5 : automatic recharge, controlled by the processor
- Event t6 : battery recharging
- Event t7 : end of recharge
- Event t8 : end of measurement approx. 30 sec after full charge recognition
- Event t9 : battery disconnected

Process-Timing

t0-t1	Delay	Until battery is connected.
t1-t2	Measurement	Approx. 20 sec.
t2-t3	Charging	Until 100% fullcharge of the battery Time depends on precharging state and charging current From 1 min. to approx. 60 min. at 1C (120 min. at 0.5C, 30 min at 2C)
t3-t4	Measurement	Approx. 30 sec
t4	Measurement	Battery fault detection
t4-t5	Delay	Until next recharge approx. 1 hour (MC-controlled)
t5-t7	Charging	Recharge (similar to t1-t3)

Application:

Power Supply: V_{in}

As supply voltage V_{in} use a rectified 50/60Hz AC voltage pulsating with a 100/120Hz frequency. No smoothing capacitor! Calculation of transformer voltage: approx. 1.9V x nominal Battery Voltage

Battery nominal-voltage	1.2	2.4	3.6	4.8	6.0	7.2	8.4	9.6	10.8	12.0	V=
Number of cells	1	2	3	4	5	6	7	8	9	10	
V_{in} typ.	7	7	9	10	12	14	16	18	20	22	V_{eff}

Battery Voltage: R9

Resistor R9 determines the range of the battery voltage (unlimited number of cells).

Calculation of R9:

$$V_{nom} = 1,2 * \left(1 + \frac{R_9}{R_{10}} \right) \quad R_9 = R_{10} * \left(\frac{V_{nom}}{1,2} - 1 \right)$$

R9@R10=33k

Battery nominal-voltage	1.2	2.4	3.6	4.8	6.0	7.2	8.4	9.6	10.8	12.0	V=
Number of cells	1	2	3	4	5	6	7	8	9	10	
Resistor R9	1	33	66	100	133	166	199	232	265	298	KOhm

Charge Current: R8//R19

The charge controller needs a current with pulsating waveform, e.g. rectified line with 100/120Hz frequency. Calculation of current: $I_{charge} = U_{ref} / (R8 \text{ parallel to } R19)$ with $U_{Ref} = 0.38V$

Charge Mode: MT1, MT2

Selection of charge mode (MT1, MT2 settings) see Table 1 page 3.

Operating Instructions:

- 1) Power supply on: 1 beep and green LED (LED 1) on (standby).
- 2) Battery connected: beep 2 times and red LED (LED 2) on. (not protected against false polarity!)
- 3) Battery fully charged: 1 beep and red LED off.
- 4) Battery fault: 5 short beep and red LED flashing.
- 5) Interrupt: 3 times 2 short beep.
- 6) Battery disconnected: last signal repeated (full or defective).
- 7) During charge: click with 1 sec period and red LED on (if BE = high)

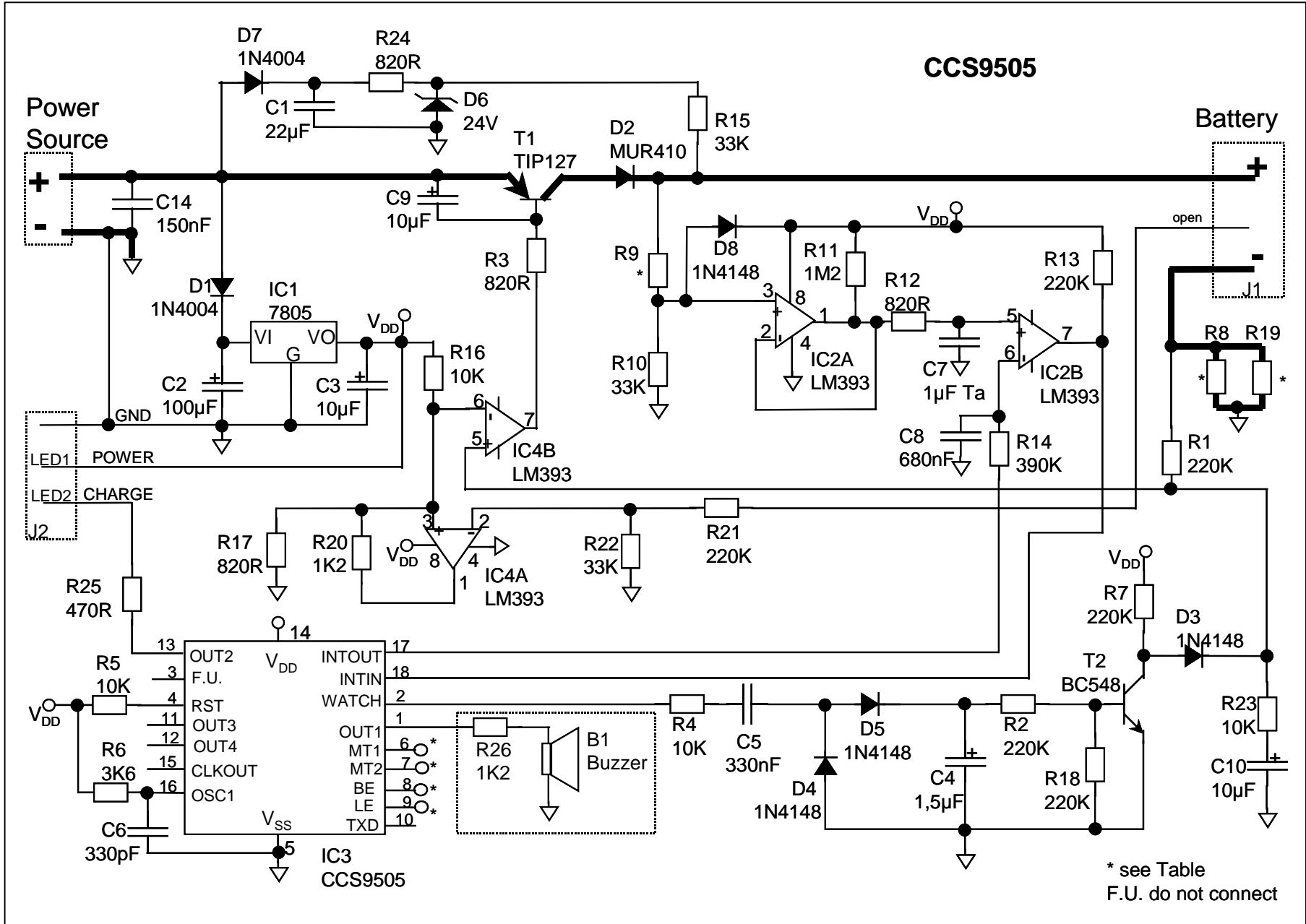

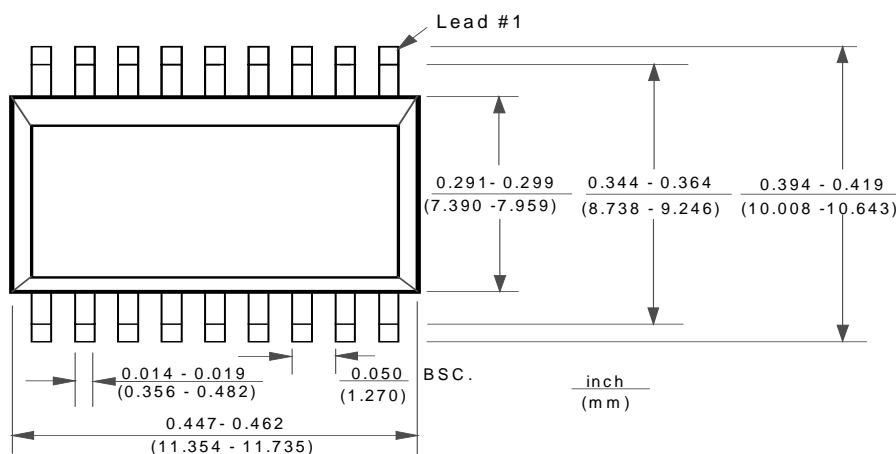
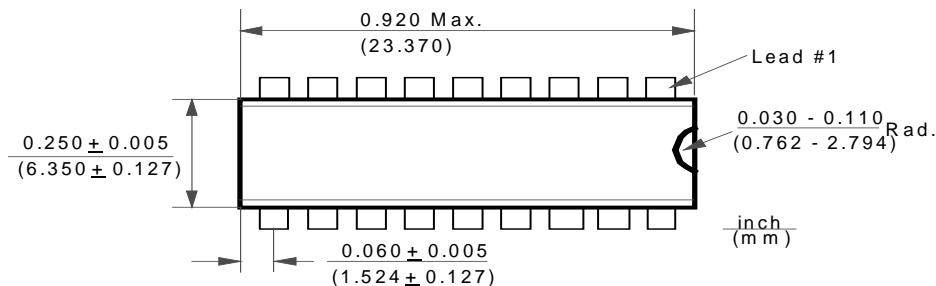
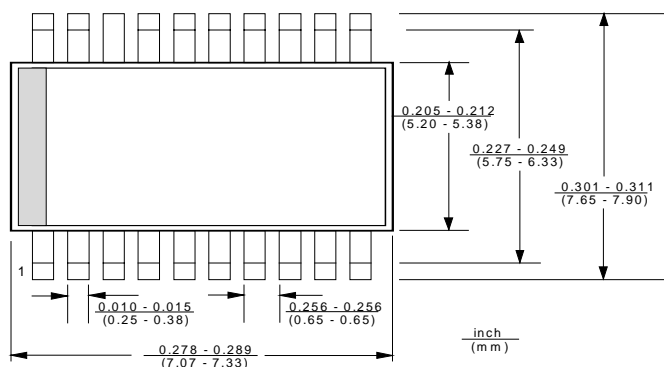
Package:**18 - Lead Plastic Dual In-line DIP 18****18 - Lead Plastic Surface Mount SOIC -Wide SMD****20 - Lead Plastic Surface Mount SSOP**

Sales office:

Producer:

≡ BTI ≡ Rudolfstrasse 14
A-8010 Graz, AUSTRIA
Tel: (+43/316) 32 60 31
Fax: (+43/316) 38 18 08
e-mail: info@bticcs.com
<http://www.bticcs.com>

BTI does not assume any responsibility for use of any circuitry described, no circuit patent licenses are implied, and BTI reserves the right, at any time without notice, to change said circuitry or specifications.